

FE50HH SERIES - 1/2 HP HIGH HEAD EFFLUENT PUMP

APPLICATIONS

For use in dewatering, water transfer, and septic wastewater removal



FEATURES

- Heavy-duty epoxy coated cast iron housing for high strength and heat dissipation
- Designed for continuous duty
- Upper and lower ball bearings for long life
- Energy-efficient PSC motor with thermal overload protection
- Unique cloverleaf intake design allows higher flow with 3/4" (19 mm) diameter solids handling
- Ideal for high-head performance in vault applications while maintaining high flow and clog resistance using a cast iron non-clog impeller
- 2" FNPT discharge (51 mm)
- Three-year warranty
- Manual or automatic switch options for application flexibility
- 140 °F (60 °C) maximum liquid temperature rating
- cCSAus listed



FE50HH-M

FE50HH-T



SERIES SPECIFICATIONS

Model	Volts	Hz	Amps		Watts	Performance (GPM / Liters per Minute @ Height)							Shut-Off	
			FLA	Start		5 ft / 1.5 m	10 ft / 3.0 m	15 ft / 4.6 m	20 ft / 6.0 m	30 ft / 9.1 m	40 ft / 12.2 m	50 / 15.2 m	ft / m	PSI / Bar
FE50HH-M-30	115	60	10	18	1100	50 / 189	48 / 182	46 / 174	43.5 / 165	33.9 / 128	22.5 / 85	7.5 / 28	53 / 16.2	22.9 / 1.6
FE50HH-T-30														

Item No.	Model	HP	Volts	Switch Type/Operations	On Level	Off Level	Cord	Weight
700201	FE50HH-M-30	1/2	115	Manual	-	-	30' 9.1 m	36.4 lbs 16.5 kg
700202	FE50HH-T-30	1/2	115	Piggyback Tethered Float	12" - 15" 30.5 cm - 38.1 cm	6" - 8" 15.2 cm - 20.3 cm	30' 9.1 m	37.7 lbs 17.1 kg
700203	FE50HH-M-50	1/2	115	Manual	-	-	50' 15.2 m	36.4 lbs 16.5 kg
700204	FE50HH-T-50	1/2	115	Piggyback Tethered Float	12" - 15" 30.5 cm - 38.1 cm	6" - 8" 15.2 cm - 20.3 cm	50' 15.2 m	37.7 lbs 17.1 kg

FE50HH SERIES - 1/2 HP HIGH HEAD EFFLUENT PUMP

ENGINEERING DATA

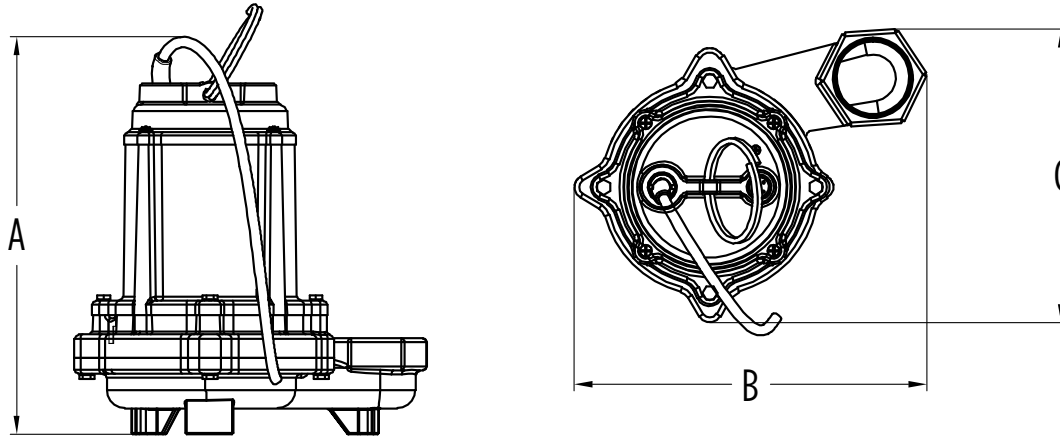

Model	A	B	C
FE50HH-M-30			
FE50HH-T-30	8.07" 20.50 cm	7.75" 19.69 cm	4.29" 10.90 cm
FE50HH-M-50			
FE50HH-T-50			

PERFORMANCE DATA

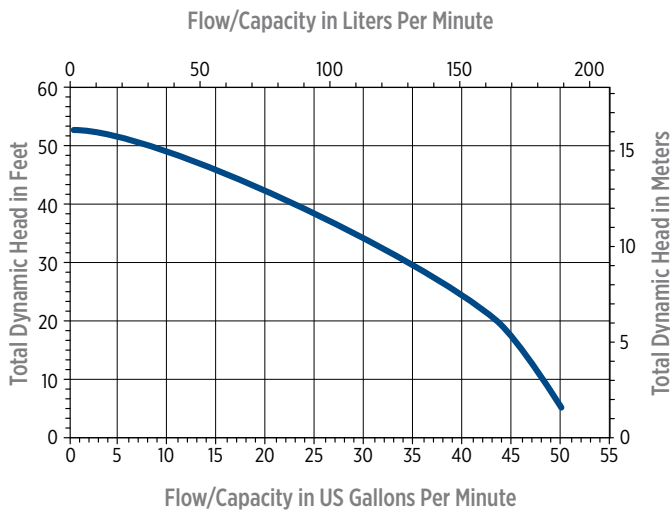

CONSTRUCTION

Cover	Epoxy-coated cast iron
Motor Housing	Epoxy-coated cast iron
Impeller Material	Cast iron
Impeller Type	Non-clog
Volute	Epoxy-coated cast iron
Mechanical Shaft Seal	Nitrile with carbon and ceramic faces
Fasteners	Stainless steel
Shaft	Stainless steel
Bearings	Upper and lower ball bearing
Power Cord	SJTW *SJTOW
RPM	3450

* FE50HH-T model piggyback switch cord type