

FBSE33 SERIES - 1/3 HP SUMP/EFFLUENT PUMP

APPLICATIONS

- Light effluent or basement sump application wastewater removal especially for new builder installations

FEATURES

- All cast iron construction – sturdy design for cooling and long life
- Oil Filled PSC motor – provides plenty of power and efficiency
- Screened intake with 3/8" solids handling capability - light effluent, greywater, or sump application flexibility
- Upper and lower ball bearings – provides quiet and robust operation
- 95°F (35°C) liquid temperature rating - gives application flexibility
- cCSAus
- 1-1/2" FNPT discharge



FBSE33-V

FBSE33-T



SERIES SPECIFICATIONS

Model	HP	Volts	Hz	Amps	Watts	Max. Water Temp.	GPM / Liters per Minute @ Height				Shut-Off	
							5' 1.5 m	10' 3 m	15' 4.6 m	20' 6 m	ft / m	PSI / Bar
FBSE33-T-15	1/3	115	60	4.3	400	95°F (35°C)	50/189	41/155	31/117	16/61	25 / 7.6	10.8/0.74
FBSE33-V-15												

Item No.	Model	HP	Volts	Switch Type / Operation	On Level	Off Level	Cord	Weight (lbs/kg)
700101	FBSE33-T-15	1/3	115	Piggyback Tethered Float	12"-14"/30.5 cm-35.6 cm	4"-6"/10.2cm-15.2 cm	15' / 4.6m	19/8.6
700102	FBSE33-V-15	1/3	115	Piggyback Vertical Float	6"-8"/15.2 cm-20.3 cm	1.8"-3.8"/4.6 cm-9.7 cm	15' / 4.6m	19/8.6

FBSE33 SERIES - 1/3 HP SUMP/EFFLUENT PUMP

ENGINEERING DATA

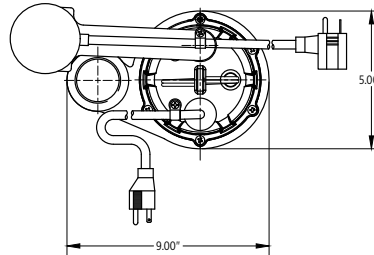
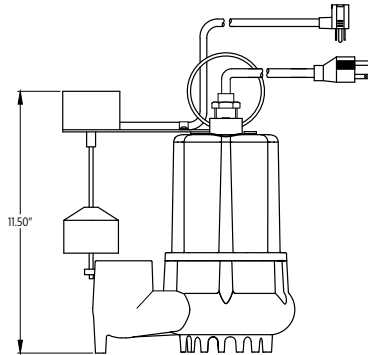
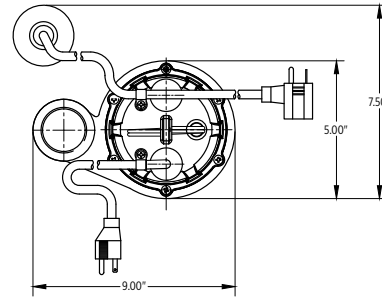
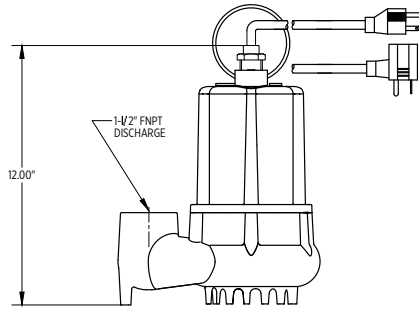

PERFORMANCE DATA

Sump/Effluent Pump Composite Performance Curves

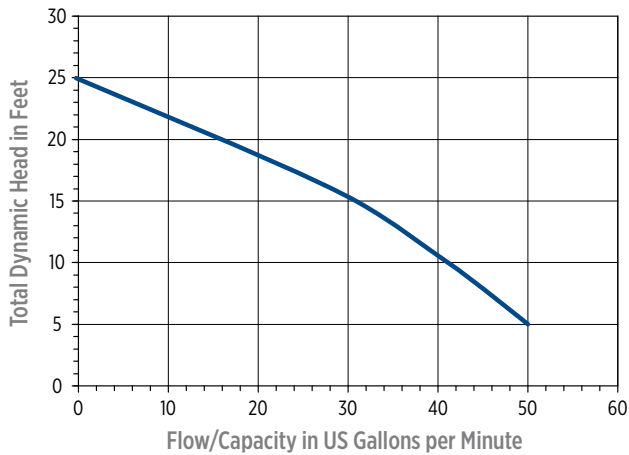

CONSTRUCTION

Cover	Epoxy Coated Cast Iron
Motor Housing	Epoxy Coated Cast Iron
Impeller Design	Vortex
Impeller Material	Epoxy Coated Cast Iron
Volute	Epoxy Coated Cast Iron
Mechanical Shaft Seal	Carbon/Ceramic/Nitrile
Fasteners	Stainless Steel
Shaft	Stainless Steel
Bearings	Upper and Lower Ball Bearings
Power Cord	SJTW