

# INDUSTRIAL E SERIES

## BAG HOUSINGS

---



Pentair Industrial® E Series Single Liquid Bag Housings effectively remove dirt, pipe scale, and other substances from process liquids. Constructed from 304 or 316L stainless steel these housings offer outstanding durability and corrosion resistance across a wide variety of industrial and commercial applications.

Quality workmanship and design assure clean effluent and consistent, reliable performance. Unfiltered liquid enters the housing above the filter bag or strainer basket, fills the interior of the housing and continues through the bag or strainer basket. Solids are trapped inside the filter bag or strainer and are easily removed when the housing is serviced. The simple to operate band clamp closure makes bag change-outs quick and easy.

### FEATURES/BENEFITS

---

Flow rates up to 135 gpm (511 Lpm)  
Accepts #1, #2, #3, and #4 size bag filters, depending on model  
125 psi (8.6 bar) pressure rating

Each housing is factory hydro-tested  
Band clamp closure  
Adjustable support legs included  
Polished external finish

### APPLICATIONS

---

Water  
General Industrial  
Chemical

Oil & Gas  
Food & Beverage  
Commercial

## SPECIFICATIONS

Pressure Rating	125 psi @ 300°F (8.6 bar @ 148.9°C)
Connections	2" NPT (ES1 & ES2); 1" NPT (ES3 & ES4)
Housing Lid	Band clamp closure
Lid Seal/Basket Seal	EPDM
Vent	1/4" NPT
Construction	304 or 316L, polished external finish
Basket Material	304 SS with 1/8" (3mm) perforations for 304 SS housings 316L SS with 1/8" (3mm) perforations for 316L SS housings
Bag Sizes	#1, #2, #3, or #4 liquid bags accepted depending on model
Base	Adjustable tripod leg assembly

## DIMENSIONS

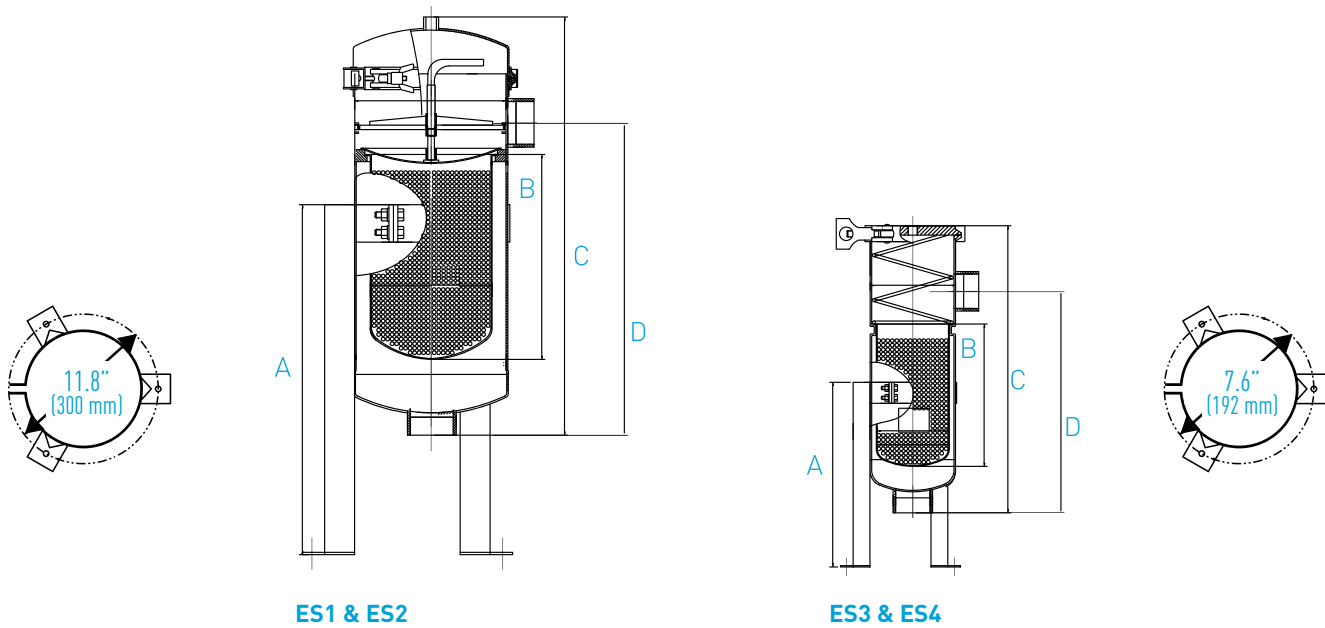

MODEL	BAG SIZE	NOMINAL FLOW RATE	DIMENSIONS				WEIGHT		
				A	B	C	D		
ES1	1	70 gpm (265 Lpm)	IN	19.7	15.0	27.6	20.5	LBS	35
			MM	500	380	700	520	KG	16
ES2	2	135 gpm (511 Lpm)	IN	27.6	28.3	41.3	34.3	LBS	46
			MM	700	720	1050	870	KG	21
ES3	3	25 gpm (95 Lpm)	IN	13.8	7.5	15.7	12.9	LBS	26
			MM	350	190	400	328	KG	12
ES4	4	35 gpm (132 Lpm)	IN	19.7	13.4	21.3	18.4	LBS	29
			MM	500	340	540	468	KG	13

*All dimensions are approximate.*

## ORDERING INFORMATION

To create your ordering part number, use the part number configurator below.  
*Custom configurations available. Please contact customer service.*

### HOUSING EXAMPLE: ES12NA410

ES Housing (ES), #1 basket (1), 2" (2), NPT connection (N)  
Outlet connection located on bottom (A), 304 Stainless steel (4), 125 psi (10)

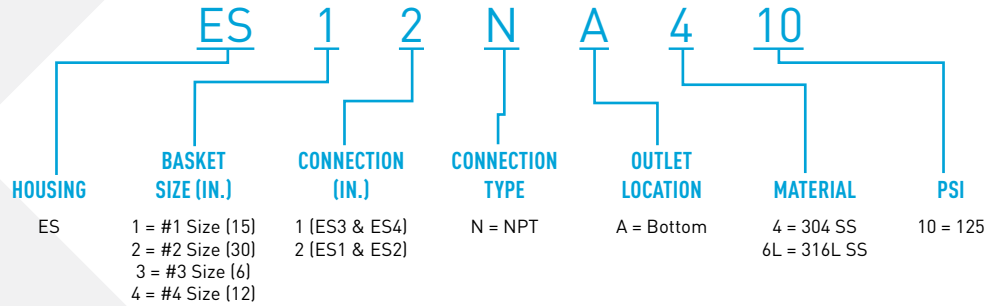



**WATER QUALITY SYSTEMS**

5730 NORTH GLEN PARK ROAD, MILWAUKEE, WI 53209

P: 262.238.4400 | F: 262.238.4404

PENTAIRINDUSTRIAL.COM

CUSTOMER CARE: 800.279.9404 | [tech-support@pentair.com](mailto:tech-support@pentair.com)

© 2016 Pentair Residential Filtration, LLC. All rights reserved.

<sup>§</sup>For a detailed list of where Pentair trademarks are registered, please visit [waterpurification.pentair.com/brands](http://waterpurification.pentair.com/brands).

Pentair trademarks and logos are owned by Pentair plc or its affiliates. Third party registered and unregistered trademarks and logos are the property of their respective owners.

4003089 Rev F MY16