

Mini Doser™ Pump Switch

15 Amp | 120/230VAC

MODEL: REDUCED RANGE (MEDIUM ANGLE), NORMALLY OPEN ONLY

ALDERON™
Industries

Leading Edge Control Products

TECHNICAL DATA SHEET

DESCRIPTION OF OPERATION



The Mini Doser™ Pump Switch is used to turn a pump on and off in environments with temperatures up to 140° F. This product can be used for a variety of applications, including but not limited to: septic tanks, sump pits, holding tanks, pump chambers, water tanks, and any other liquid tanks. Available in 120/230VAC bare lead (no plug), 120VAC piggyback plug, and 230VAC piggyback plug, 15 Amp models.

The pump switches are mechanically operated using a mechanical switch and are activated by the ball inside the float housing. Available only in reduced range (medium angle) switching differential. For use as empty tank (normally open) configuration with multiple types of float attachments for mounting and various cable lengths.

NOTE: Check to make sure the correct pump switch is being used for the application:

Normally Open - Contacts are open while hanging down and will close on a rising liquid level. Typically used for empty tank applications.

STANDARD FEATURES

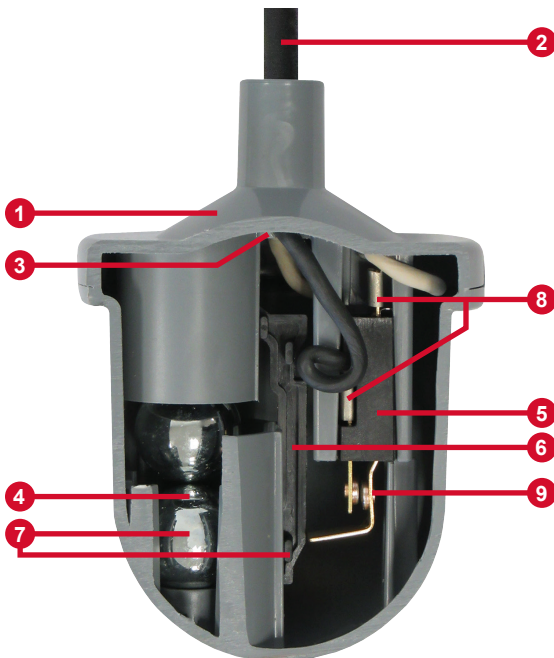

(1) **Polyvinyl Chloride (PVC) Housing** - Designed for temperatures up to 140° F, resistant to harsh chemicals, and withstands high impact.

(2) **Cable Type** - SJOOW (UL/CSA), 14 gauge, 2-conductor, flexible, and water/oil resistant. Available in 120/230VAC bare lead (no plug), 120VAC piggyback plug, and 230VAC piggyback plug, 15 Amp models.

(3) **Internal Wiring** - Epoxy moisture seal technology for protection from water intrusion.

(4) **Ball** - Located inside the float housing and used to actuate the mechanical switch, this model uses two balls to operate the pump switch.

(5) **Mechanical Switch** - Activated by the ball inside the float housing causing the contacts to open or close.

(6) **Actuator Arm** - As the float tilts above/below horizontal, the ball inside the housing will activate or deactivate the actuator arm causing the mechanical switch to turn on/off.

(7) **Switching Differential** - Reduced range (medium angle; 40°) models for a variety of applications. The medium angle switching differential is created by using two balls to activate or deactivate the actuator arm.

(8) **Innovative Mechanical Design** - Using mechanically activated snap action contacts eliminates the hazardous mercury for an environmentally safe product.

(9) **Switching Contacts** - Heavy duty switching contacts will open or closed when the mechanical switch is activated or deactivated.

(10) **Omni-Directional (not shown)** - Not sensitive to either rotation or turbulence. The float switch will operate at the designed angle regardless of the direction of the tilt.

SPECIFICATIONS

Mini Doser™ Pump Switch



Primary Voltage

120VAC or 230VAC, 60 Hz
(voltage depends on model/part number)

Amperage

15 Amps

Float Housing Material

Polyvinyl Chloride (PVC)

Float Housing Size

3.25 inches (diameter) x 4.55 inches (length)

Cable Type

SJOOW (UL/CSA), 14 gauge, 2-conductor, flexible, and water/oil resistant

Connection Types

Bare Lead (no plug; 120/230VAC)
Piggyback Plug (120VAC or 230VAC)

Operating Temperature

0 - 140° F

Switching Differential

40° total (reduced range/medium angle)

Switch Configuration

Single Pole, Single Throw (NO only)

Certifications

UL (US and Canada)

Three-Year Limited Warranty

NOTE: The Mini Doser™ pump switch must be used with pumps that provide integral thermal overload protection.

MECHANICAL DRAWING

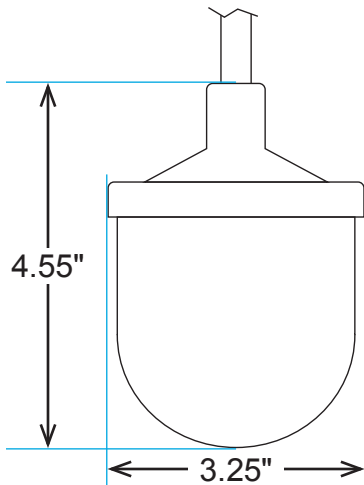

APPLICATION EXAMPLE

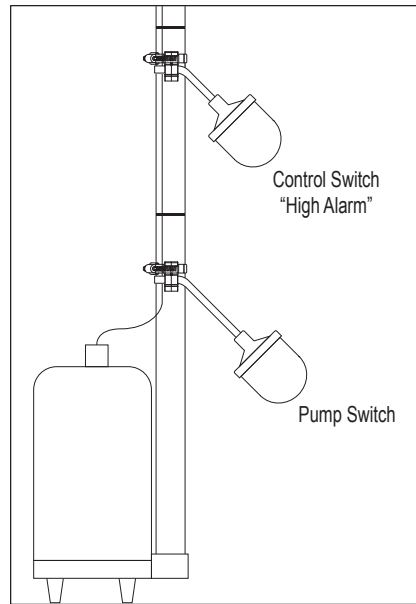

EMPTY TANK
(normally open example)

TETHER LENGTH GUIDE

CAUTION: USE A GUIDE ONLY, ACTUAL RANGES MAY VARY
(Reference Only - Testing Must Be Performed for Actual Ranges)

Tether Length (inches)	3.5"	4.0"	6.0"	8.0"	10.0"	12.0"	16.0"	20.0"	24.0"
Pumping Range (inches) N/A = Model Not Available									
Narrow Angle	N/A	N/A	N/A	N/A	N/A	N/A	N/A	N/A	N/A
Medium Angle	3.68"	3.75"	4.5"	5.25"	6.25"	7.5"	10.5"	13.5"	16.5"
Wide Angle	N/A	N/A	N/A	N/A	N/A	N/A	N/A	N/A	N/A

Pump Switches - MINIMUM Recommended Tether of 3.5"

Multiple float switches with pipe clamps are used for a variety of applications to empty a tank or use as high level alarms.

Normally Open (empty):

Control Switch / Top Float = High Alarm
Pump Switch / Bottom Float = Start/Stop Pump

ORDERING INFORMATION

For a complete list of standard products with pricing, refer to the current year price sheet or visit alderonind.com for more information.

PART NUMBER	DESCRIPTION (120/230VAC, Bare Lead or Piggyback Plug 15 Amp)
7140	15' Mini Doser™ Medium Angle Pump Switch, 120VAC Piggyback Plug, Pump Down, Stainless Steel Pipe Clamp, Boxed
7141	20' Mini Doser™ Medium Angle Pump Switch, 120VAC Piggyback Plug, Pump Down, Stainless Steel Pipe Clamp, Boxed
7182	15' Mini Doser™ Medium Angle Pump Switch, 230VAC Piggyback Plug, Pump Down, Stainless Steel Pipe Clamp, Boxed
7183	20' Mini Doser™ Medium Angle Pump Switch, 230VAC Piggyback Plug, Pump Down, Stainless Steel Pipe Clamp, Boxed
7143	15' Mini Doser™ Medium Angle Pump Switch, 120/230VAC Bare Leads, Pump Down, Stainless Steel Pipe Clamp, Boxed
7144	20' Mini Doser™ Medium Angle Pump Switch, 120/230VAC Bare Leads, Pump Down, Stainless Steel Pipe Clamp, Boxed