

SEWAGE PUMPS

Model: SW50



Features

- Heavy duty cast iron construction
- Oil-filled continuous duty PSC motor (1Ph)
- Vortex cast iron impeller
- 2" solids handling

Specifications

Physical Data:

DISCHARGE SIZE	2" N.P.T. 3" NPT Optional
IMPELLER TYPE	9 Vane Vortex -Cast Iron
CABLE LENGTH	20'

Liquid Handling:

SOLIDS SIZE	2"
MAXIMUM LIQUID TEMP.	104°F – Intermittent
ACCEPTABLE PH RANGE	6-8

Technical Data:

MOTOR HOUSING	Cast Iron
CASING	Cast Iron
IMPELLER	Cast Iron
MOTOR SHAFT	AISI 1045
HARDWARE	SST
"O" RINGS	NBR
SEAL	Single Mechanical, Carbon Ceramic
UPPER BEARING	6202
LOWER BEARING	6203

Electrical Data:

R.P.M.	3450
MOTOR TYPE	PSC
GEN INSULATION CLASS	B
STATOR WINDING CLASS	B
MAXIMUM STATOR TEMP	130°C
VOLTAGE TOLERANCE	±10%
MOTOR PROTECTION	Thermally Protected
HP	1/2 HP
VOLTAGE	115/230/208
PHASE	1 and 3
SERVICE FACTOR	1

Specifications

Model	HP	Volt	Ph	Nema Start Code	Full Load Amps	Cord Size	Cord Type	Cord O.D. Inches (mm)
SW50M1-20	1/2	115	1	P	9.5	16AWG/3C	SJTOW	.325-.360
SW50M2-20	1/2	230	1	P	4.8	16AWG/3C	SJTOW	.325-.360
SW50M3-20	1/2	230	3	R	3.0	16AWG/4C	SJTOW	.325-.360
SW50M5-20	1/2	208	1	P	5.2	16AWG/3C	SJTOW	.325-.360
SW50M6-20	1/2	208	3	R	3.1	16AWG/4C	SJTOW	.325-.360

Features

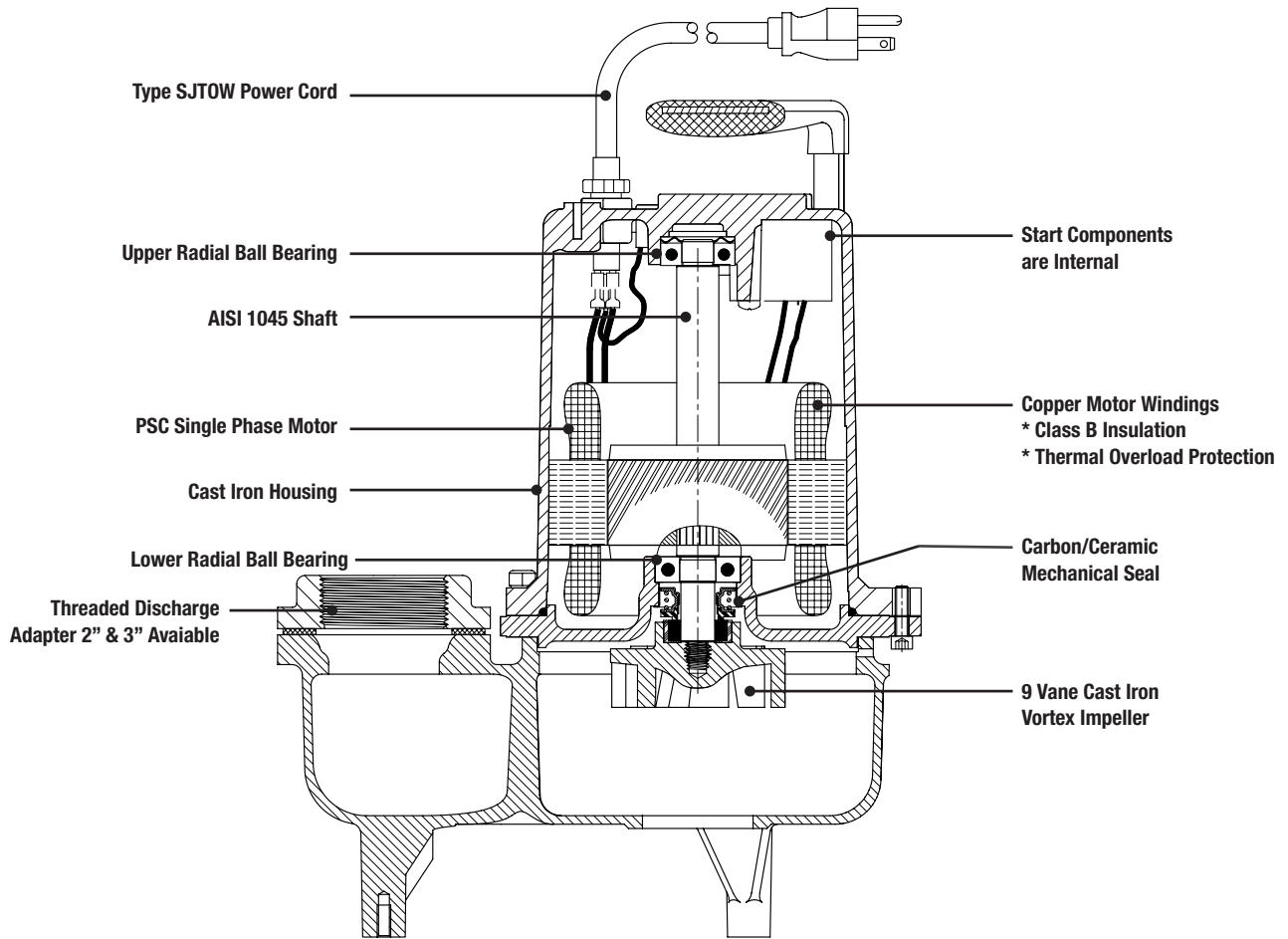

Dimensional Data

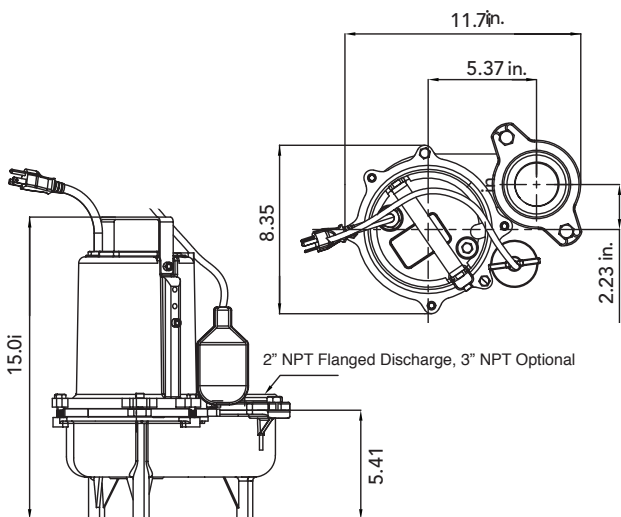

Performance Curve

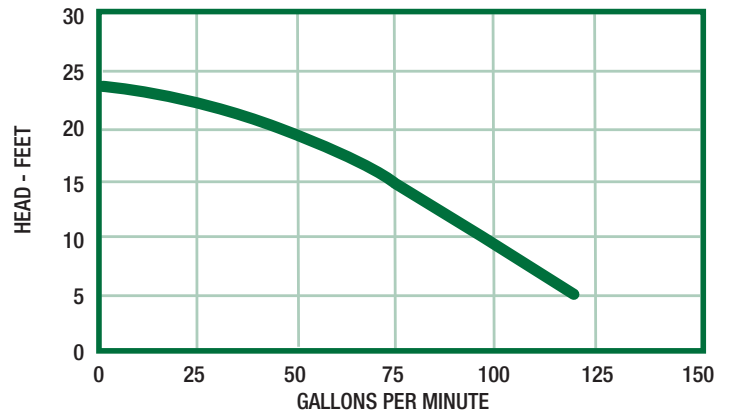

Ashland

P U M P

Honest, Professional, Dependable

1899 Cottage Street, Ashland, Ohio 44805

Telephone: 855 281-6830 · Fax: 877 326-1994 · ashlandpump.com