



LB SERIES

Semi-Vortex Wastewater Pump

SPECIFICATIONS

✓ FEATURES



LB-480 LB-480A LB-800(T) LB-1500(T)

- Highly efficient, continuous duty Air-filled, copper wound motor with class E,B insulation minimizes the cost of operation.
- Built in thermal protection prevents motor failure due to overloading, accidental run-dry and single phasing in three phase units.
- Double inside mechanical seals with silicon carbide faces running in an oil filled chamber provide for one the most durable seal designs available.
- Double shielded, permanently lubricated, high temperature C3 ball bearings rated for a provide for extended operational life.
- Model LB-480A & LB-800A Automatic Submersible pump performs like the non-automatic version in every aspect of construction site usage requiring a tough and durable pump
- Slim design allows pumps to fit into 8" pipes. (Manual type only)



✓ APPLICATIONS

- Residential, commercial, industrial wastewater and site drainage.
- Decorative waterfalls and fountains.
- Raw water supply from lakes or rivers.
- Sediment removal from small sumps or basins.

✓ SPECIFICATIONS

LB SERIES		STANDARD	OPTIONS
Discharge Size		2" - 3" NPT (50 - 80mm)	
Horsepower Range		1/2 - 2 HP (0.40-1.5kW)	
Performance Range	Capacity	15.9 - 111.0 GPM (0.06 - 0.42m ³ /min)	
	Head	13.1 - 68.9ft. (4.0 - 18.9m)	
Maximum Water Temperature		104°F (40°C)	
Materials of Construction	Casing	Butadiene Rubber + Natural Rubber + Steel (LB[T]-1500)	
	Impeller	Urethane Rubber High Chrome Cast Iron* (*LB[T]- 1500)	
	Shaft	403 Stainless Steel	
	Motor Frame	Aluminum Alloy	
	Fastners	304 Stainless Steel	
Mechanical Seal		Silicon Carbide	
Elastomers		NBR (Nitrile Butadiene Rubber)	
Impeller Type		Semi-Vortex, Solid Handling	
Solids Handling Capability		0.236" (6.0mm)	
Bearings		Prelubricated, Double Shielded	
Motor Nomenclature	Type, Speed, Hz	Air Filled, 3600RPM, 60Hz	
	Voltage, Phase	115 /230V, 1 Phase	
	Insulation	Class E, B	
Accessories		Submersible Power Cable, 32' - 50' (10 - 15m)	Length as required
Operational Mode		Manual, Automatic (LB-480A/800A)	TS-301 Float Switch



LB - SERIES SEMI-VORTEX - DEWATERING PUMP

PERFORMANCE RANGE

GROUP PERFORMANCE RANGE

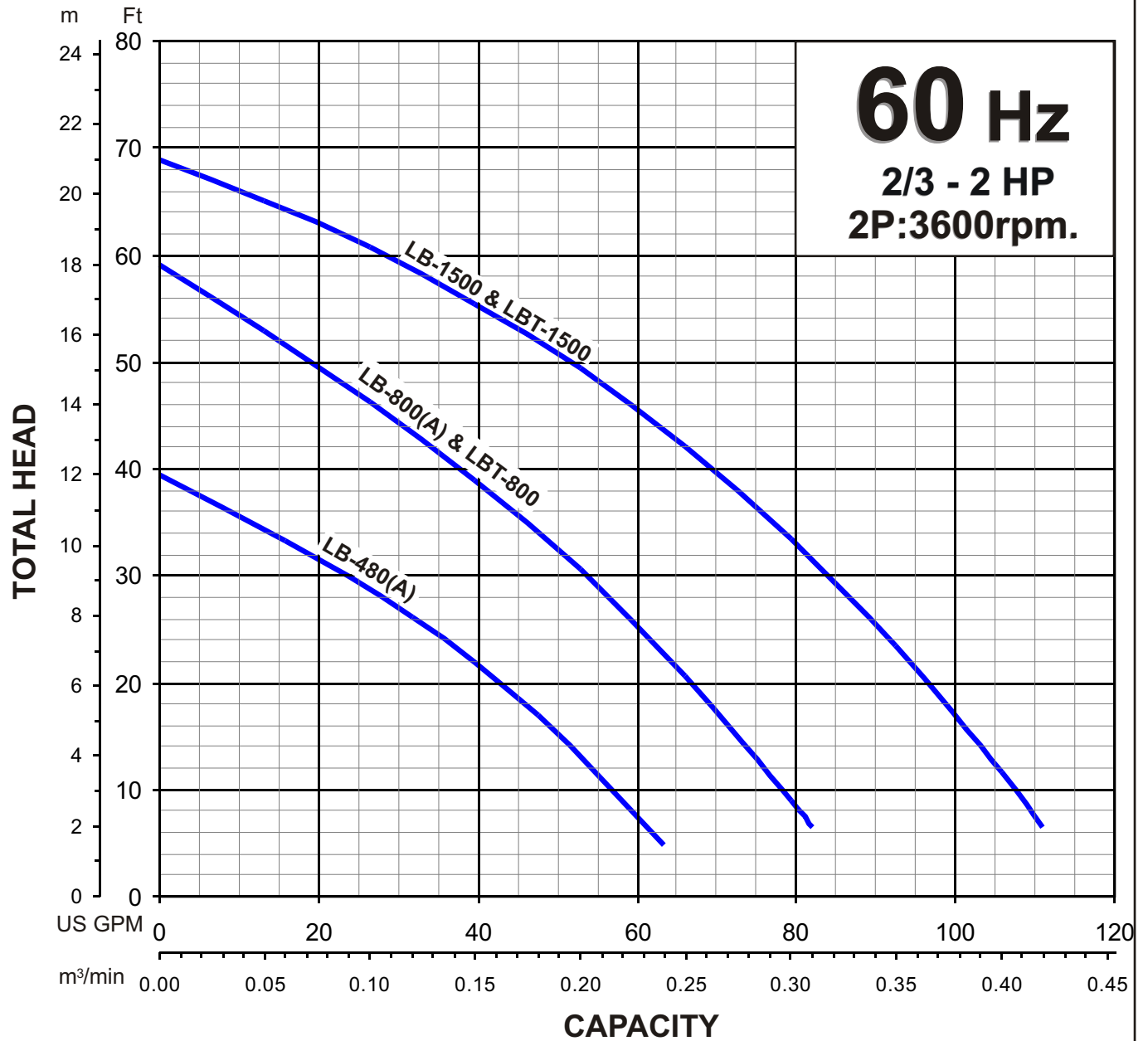



LB - SERIES SEMI-VORTEX - DEWATERING PUMP

PERFORMANCE CURVE

MODEL	BORE	HP	KW	RPM	SOLIDS DIA	LIQUID	SG.	VISCOSITY	TEMP.
LB(Z)-800(A)-62	2"/50mm	1	0.75	3316	0.236"/6mm	Water	1.0	1.123 cSt.	60°F
PUMP TYPE		PHASE	VOLTAGE	AMPERAGE		HZ	STARTING METHOD		INS. CLASS
Semi-Vortex - Dewatering Pump		Single	110/115, 220/230	10.8 / 10.5 , 5.4 / 5.2		60	Capacitor Start		E
CURVE No.	DATE	PHASE	VOLTAGE	AMPERAGE		HZ	STARTING METHOD		INS. CLASS
-	-	-	-	-		-	-		-

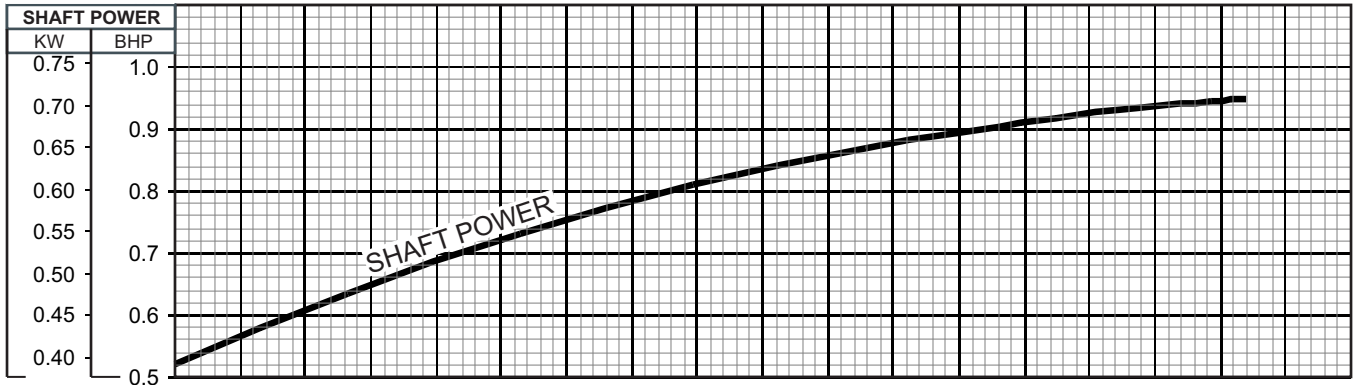
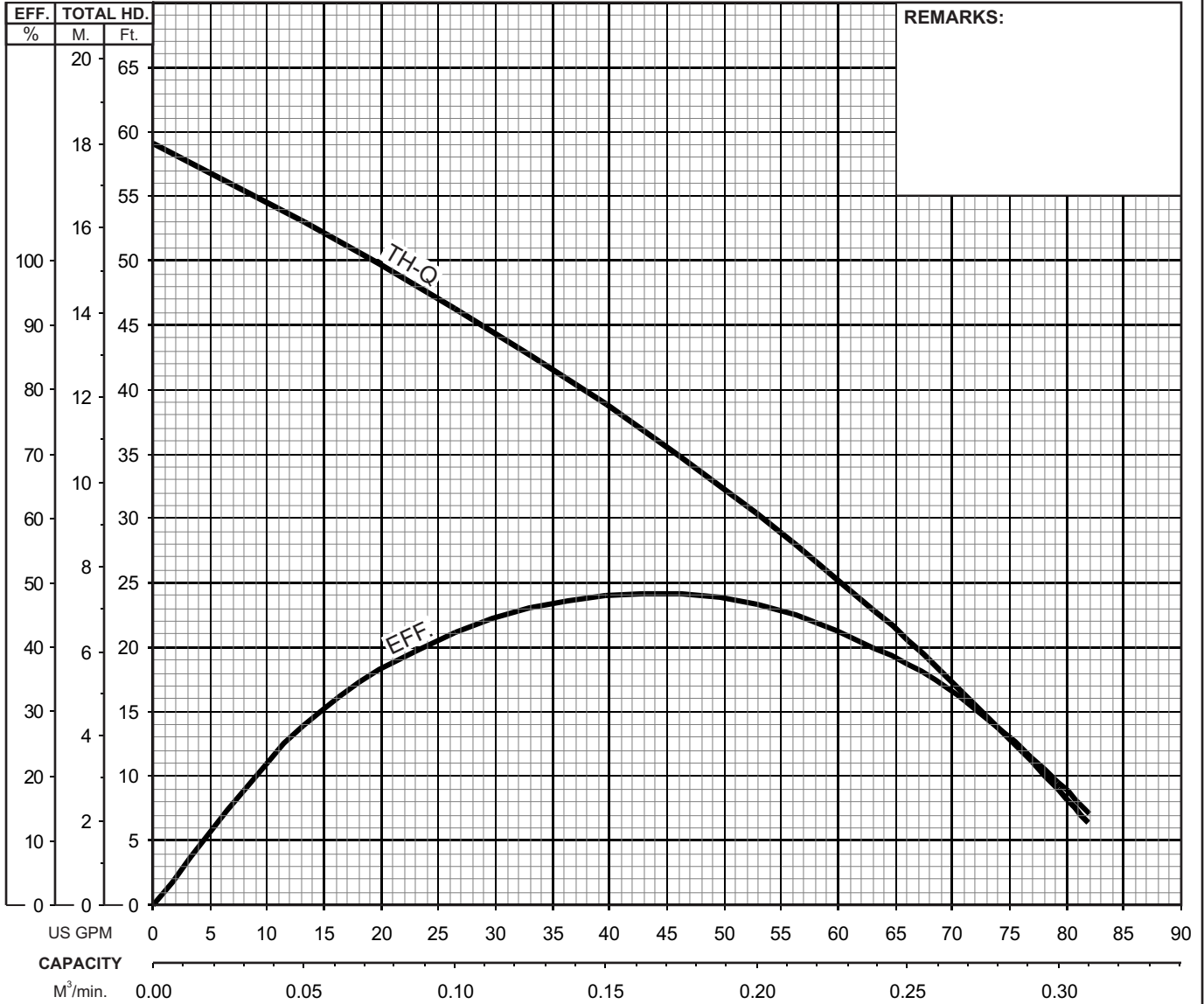



LB - SERIES
SEMI-VORTEX - DEWATERING PUMP

DIMENSIONS

LB-800-62
LBT-800-61

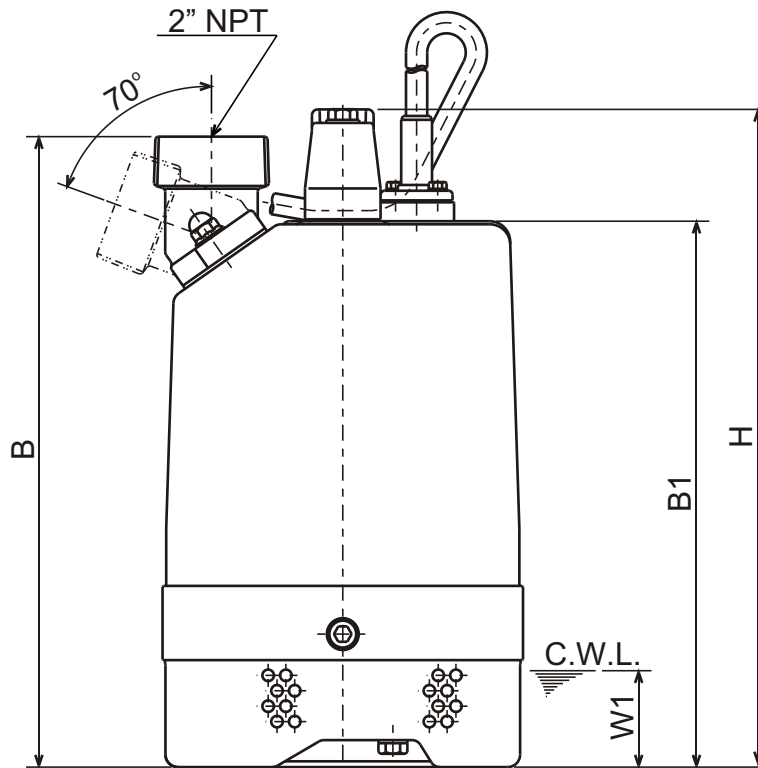
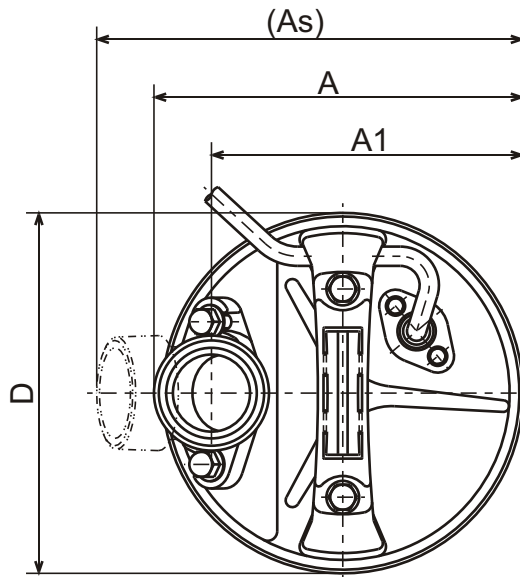

C.W.L. : Continuous running Water Level

DIMENSIONS :USCS (Inch)

Model	HP	NOM. SIZE	Pump & Motor								C.W.L. W1	Wt. (lbs.)
			A	As	A1	B	B1	D	H			
LB-800-62	1	2"	7 9/16	8 11/16	6 3/8	12 7/8	11 1/8	7 3/8	13 7/16	2	29	
LBT-800-61	1	2"	7 9/16	8 11/16	6 3/8	12 7/8	11 1/8	7 3/8	13 7/16	2	28	

DIMENSIONS :METRIC (mm)

Model	kW	NOM. SIZE	Pump & Motor								C.W.L. W1	Wt. (kg)
			A	As	A1	B	B1	D	H			
LB-800-62	0.75	50	192	221	162	327	283	187	341	50	13.1	
LBT-800-61	0.75	50	192	221	162	327	283	187	341	50	12.8	

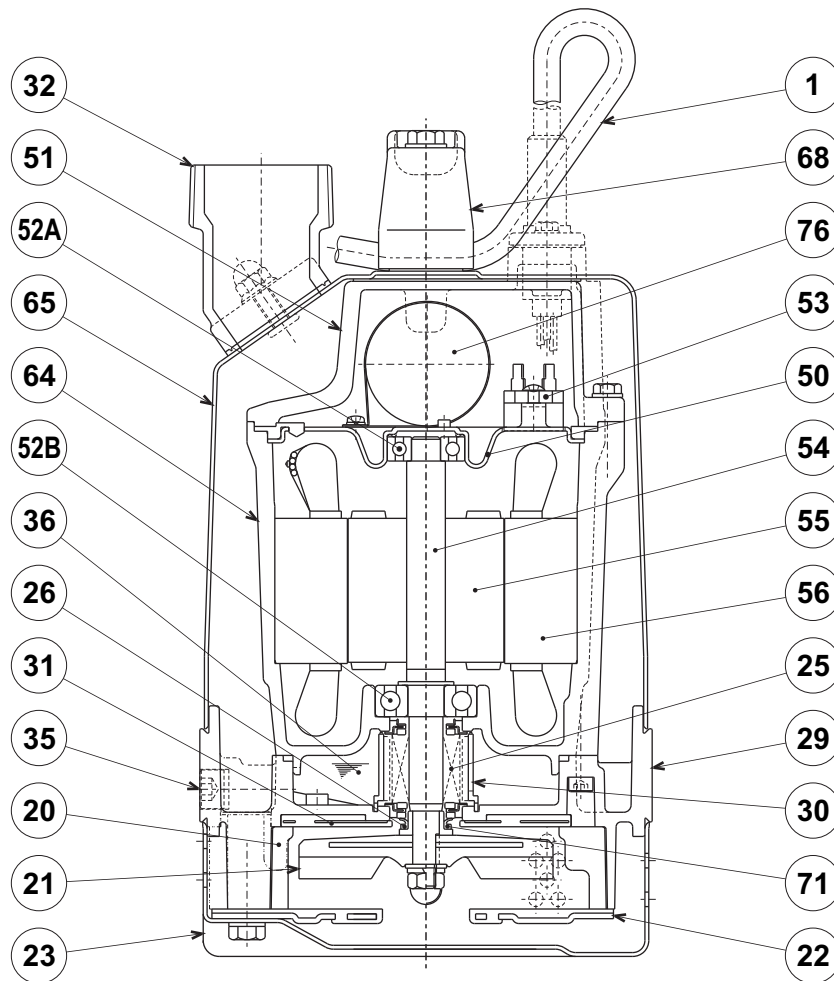
LB-800-62

ITEM#	DESCRIPTION	MAIN MATERIAL / NOTE	RELATED ASTM, AISI CODE	RELATED EN CODE	Q'TY
1	Power Cable	PVC Sheath AWG14/3-50ft			1
20	Pump Casing	Butadiene Rubber + Natural Rubber			1
21	Impeller	Urethane Rubber			1
22	Suction Cover	Urethane Rubber + Steel (Cold Rolled)	(A109/A1008)	(EN 10130)	1
23	Suction Strainer	Steel (Cold Rolled)	A109/A1008	EN 10130	1
25	Mechanical Seal	Silicon Carbide / W-14VL			1
26	V-Ring	Nitrile Butadiene Rubber			1
29	Oil Casing	Aluminum Alloy Die Casting	B85 383.0	EN 1706 AC-46100	1
30	Oil Lifter	PBT Resin			1
31	Wearing Plate	Urethane Rubber			1
32	Discharge Connection	Aluminum Alloy Die Casting / NPT 2"	B85 383.0	EN 1706 AC-46100	1
35	Oil Plug	Stainless Steel	S 30400	1.4301	1
36	Lubricant	Turbine Oil ISO VG32 or SAE10W-20			
50	Motor Bracket	Steel (Electro-Galvanized)	A591	EN 10152	1
51	Motor Head Cover	Aluminum Alloy Die Casting	B85 383.0	EN 1706 AC-46100	1
52A	Upper Bearing	#6201ZZC3			1
52B	Lower Bearing	#6302ZZC3			1
53	Motor Protector				1
54	Shaft	Stainless Steel	S 40300	1.4000	1
55	Rotor				1
56	Stator				1
64	Motor Housing	Aluminum Alloy Die Casting	B85 383.0	EN 1706 AC-46100	1
65	Outer Cover	Steel (Cold Rolled)	A109/A1008	EN 10130	1
68	Handle	ABS Resin			1
71	Shaft Sleeve	Stainless Steel	S 30400	1.4301	1
76	Capacitor				1



LB-800-62
SEMI-VORTEX - DEWATERING PUMP

SAMPLE
SPECIFICATIONS

1. SCOPE OF SUPPLY -

Furnish and install TSURUMI Model LB-800-62 Submersible Pump(s). Each unit shall be capable of delivering _____ GPM (_____ m³/min) at _____ Feet (_____ m) TDH. The pump(s) shall be designed to pump wastewater, without damage during operation. The pump(s) shall be designed so that the shaft power required (BHP)/(kW) shall not exceed the motor rated output throughout the entire operating range of the pump performance curve. Pump(s) shall be of the top flow through design.

2. MATERIALS OF CONSTRUCTION -

Construction of major parts of the pumping unit(s) shall be as follows: Pump casing shall be synthetic rubber. Motor frame shall be aluminum alloy die casting. Internal and external surfaces coming into contact with the pumpage shall be protected by a fused polymer coating. All exposed fasteners shall be stainless steel. All units shall be furnished with 2" NPT discharge connector. Impellers shall be of the multi-vane, urethane rubber, semi-vortex solids handling design and shall be slip fit to the shaft. The motor shaft shall be machined to provide a positive drive of the impeller.

3. MECHANICAL SEAL -

All units shall be furnished with a dual inside mechanical shaft seal located completely out of the pumpage, running in a separate oil filled chamber and further protected by an exclusionary oil seal located between the bottom seal faces and the fluid being pumped. The oil chamber shall be fitted with a device that shall provide positive lubrication of the top mechanical seal, (down to one third of the standard oil level). The device shall not consume any additional electrical power. Mechanical seals shall rated to preclude the incursion of water up to 13.9 PSI. (32 Ft.) submergence. Units shall have silicon carbide mechanical seal faces. Mechanical seal hardware shall be stainless steel.

4. MOTOR-

The pump motor(s) shall be 1 Hp., 0.75 kW., 115 or 230 V., 60 Hz. 1 Phase and shall be NEMA MG-1, Design Type B equivalent. Motor(s) shall be rated at 10.5 or 5.2 full load amps. Motor(s) shall have a 1.15 service factor and shall be rated for 10 starts per hour. Motor(s) shall be air filled, copper wound, class E insulated with built in thermal protection. Motor shaft shall be 403 stainless steel, fitted with a replaceable, stainless steel shaft sleeve and shall be supported by two permanently lubricated, high temperature ball bearings, with a B-10 life rating at best efficiency point of 60,000 hours. Bearings on all units shall be single row, double shielded, C3, deep groove type ball bearing.

5. POWER CABLE AND CABLE ENTRANCE -

The pump power cable shall be suitable for submersible pump applications. The cable entrance shall incorporate built in strain relief, a one piece, three way mechanical compression seal with a fatigue reducing cable boot. The cable entrance assembly shall contain an anti-wicking block to eliminate water incursion into the motor due to capillary wicking should the power cable be accidentally damaged.